



Techni
ENGINEERING SOLUTIONS

IVECO DAILY MY2012

29L 11/13/15, 35S 11/13/15

35C 11/13, 40C 11/13

CODE / CODICE: 0500.6842

**COMPRESSOR / COMPRESSEUR / KOMPRES-
SOR / COMPRESSORE / COMPRESOR :**

SELTEC SP13 / 15 / 16

QUE QP13 / 15 / 16

FITTING INSTRUCTIONS

EINBAUANLEITUNGEN

INSTRUCTIONS POUR LE MONTAGE

ISTRUZIONI DI MONTAGGIO

INSTRUCCIONES DE MONTAJE

Contents

ENGLISH	4
Parts View.....	4
Parts List	5
Compressor Configurations	6
Standard Fastener Torque Values	6
Kit Details	7
Vehicle Details	7
Forward	7
Pre Installation.....	8
Crankshaft Pulley Installation.....	8
Mount Bracket Installation	9
Drive Belt.....	10
Hose Support Installation	10
Hose Installation	11
Post Installation.....	13

PARTS VIEW / VUE ÉCLATÉE / TEILEANSICHT / VISTA PARTA / IMÁGENES DE LAS PIEZAS

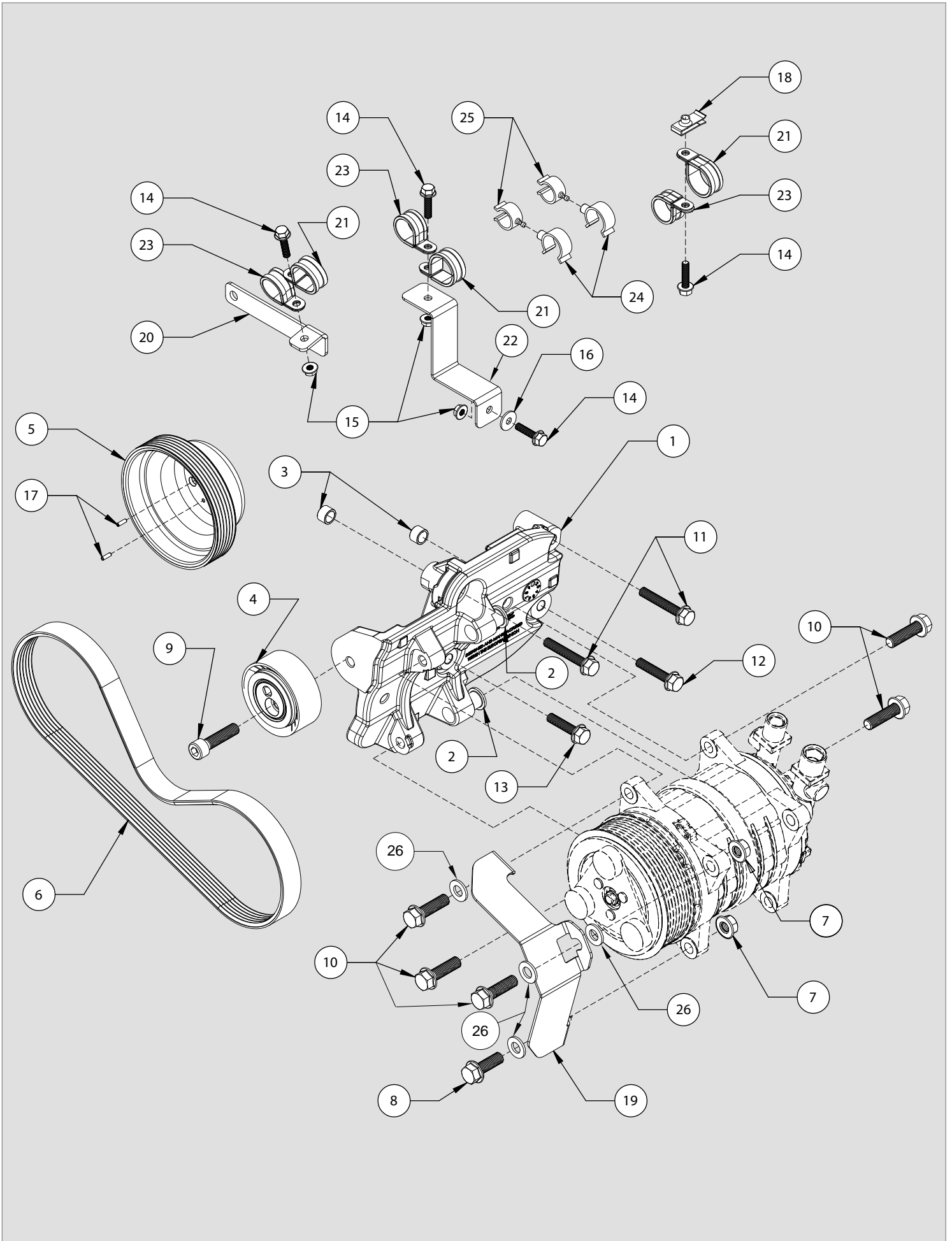

PARTS LIST / NOMENCLATURE / TEILELISTE / ELENCO DELLE PARTI / LISTA DE PIEZAS

ITEM	CODE / CODICE / KODE / CODIGO	DESCRIPTION / DESCRIZIONE / BESCHREIBUNG / DESCRIPCION	QTY.	COMMENTS
1	0440.5261	CMB - Iveco Daily 2.3 E5 MY2012	1	-
2	1710.5083	Spacer Bush - 14.8 OD x L23.5 ~ M10	2	-
3	2800.0291	Dowel Bush	2	-
4	1700.0401	Eccentric Idle Pulley 6PK x 70	1	-
5	1701.5211	Crankshaft Drive Pulley	1	-
6	0820.6181	Belt - Poly Groove 6PK 0875	1	-
7	2735.0071	Durlok Hexagon Flange Nut - M10 : 1.50	2	-
8	2705.0491	Hex flange bolt Durlok - M10 x 30 : 1.50 - 12.9	1	-
9	2705.5121	Socket cap screw M10 x 40 : 1.50 - 12.9	1	-
10	2705.0241	Hex flange bolt Durlok - M10 x 35 : 1.50 - 12.9	5	-
11	2704.0101	Hex flange bolt - M8 x 50 : 1.25 - 10.9	2	-
12	2704.0201	Hex flange bolt Durlok - M8 x 40 : 1.25 - 12.9	1	-
13	2704.0481	Hex flange bolt Durlok - M8 x 35 : 1.25 - 12.9	1	-
14	2702.0111	Hex flange bolt Durlok - M6 x 25 : 1.00 - 12.9	4	-
15	2732.0041	Hexagon flange nut Durlok - M6 : 1.00	3	-
16	2806.0501	M6 Penny Washer	1	-
17	2762.0091	Spring Pin ISO 8752 - 3 x 10	2	-
18	2732.0091	Lug nut M6	1	-
19	3020.9413	Belt Guard	1	-
20	3020.5761	Hose support bracket gearbox	1	-
21	2771.1041	P Clip 25mm	3	-
22	3020.5751	Hose Support Chassis	1	-
23	2771.1031	P Clip 19mm	3	-
24	2771.1061	Swivel clip female 90 deg 20.0 - 24.5	2	-
25	2771.1051	Swivel clip male 18 - 20	2	-
26	2809.0011	M10 Flat Washer	4	-

**COMPATIBLE COMPRESSORS / COMPRESSEURS RECOMMANDÉS / EMPFOHLENE KOMPRESSOREN
RACCOMANDATO COMPRESSORI / RECOMENDADAS COMPRESORES**

SELTEC	TM13-HS	TM15-HS	TM16-HS
Comp No	0381.0202	0381.0002	0381.0312
Valeo No.	488-45120	488-45120	488-46134
Mounting	Ear	Ear	Ear
Rotor	8PV	8PV	8PV
GL	-	-	-
Armature	3E	3E	3E
Diameter	123	123	123
Voltage	12	12	12
Orientation	V	V	V
Fitting	3/4 x 7/8	3/4 x 7/8	3/4 x 7/8
Manifold	Bolt	Bolt	Bolt

QUE	QP13-HD	QP15-HD	QP16-HD
Comp No	0391.0202	0391.0002	0391.0312
Que No.	QP15-1302	QP15-1171	QP16-1581
Mounting	Ear	Ear	Ear
Rotor	8PV	8PV	8PV
GL	-	-	-
Armature	3E	3E	3E
Diameter	123	123	123
Voltage	12	12	12
Orientation	V	V	V
Fitting	3/4 x 7/8	3/4 x 7/8	3/4 x 7/8
Manifold	Bolt	Bolt	Bolt

SANDEN	-	-	-
Comp No	-	-	-
Sanden No.	-	-	-
Mounting	-	-	-
Rotor	-	-	-
GL	-	-	-
Armature	-	-	-
Diameter	-	-	-
Voltage	-	-	-
Orientation	-	-	-
Fitting	-	-	-

NOTES

STANDARD FASTENER TORQUE VALUES

In the absence of specific torque values detailed in this fitting instruction manual, the following chart can be used as a guide to the maximum safe torque for specific size and grade of fastener.

COUPLES DE SERRAGE DES FIXATIONS STANDARDS

Si des chiffres de serrage au couple particuliers ne sont pas indiqués dans cette notice de montage, se référer au tableau suivant qui servira de guide pour le couple de sécurité maximum correspondant à une taille et un grade spécifiques de fixation.

ANZIEHMOMENTE FÜR STANDARDBEFESTIGUNGSMITTEL





Falls in dieser Einbauanleitung keine speziellen Anziehmomente angegeben sind, kann die folgende Tabelle als Richtlinie für das maximale sichere Anziehmoment für eine spezifische Größe oder Qualität von Befestigungsmitteln dienen.

VALORI STANDARD DI SERRAGGIO PER DISPOSITIVI DI FISSAGGIO

In assenza di valori specifici di coppia nel presente manuale di istruzioni, si può utilizzare la seguente tabella come guida per conoscere la coppia massima sicura in base a dimensioni e grado del dispositivo di fissaggio.

VALORES ESTÁNDAR DE LOS PARES DE APRIETE Y FIJACIÓN

En ausencia de valores para los pares de apriete específicos detallados en este manual de instrucciones de montaje, se puede utilizar la siguiente tabla como guía para consultar el máximo par de torsión seguro para un tamaño concreto y su grado de fijación.

STRENGTH								
	Max Torque		Max Torque		Max Torque		Max Torque	
Dia / Pitch	lb.ft	Nm	lb.ft	Nm	lb.ft	Nm	lb.ft	Nm
M5 x 0.80	2	3	4.5	6	6.5	9	7.5	10
M6 x 1.00	4	5.5	7.5	10	11	15	13	18
M8 x 1.25	10	13	18	25	26	35	33	45
M10 x 1.25	20	27	39	53	57	78	66	90
M10 x 1.50	18	25	37	50	55	73	63	86
M12 x 1.75	33	45	63	85	97	130	111	150
M14 x 2.00	55	75	103	140	151	205	177	240
M16 x 2.00	85	115	159	215	232	315	273	370

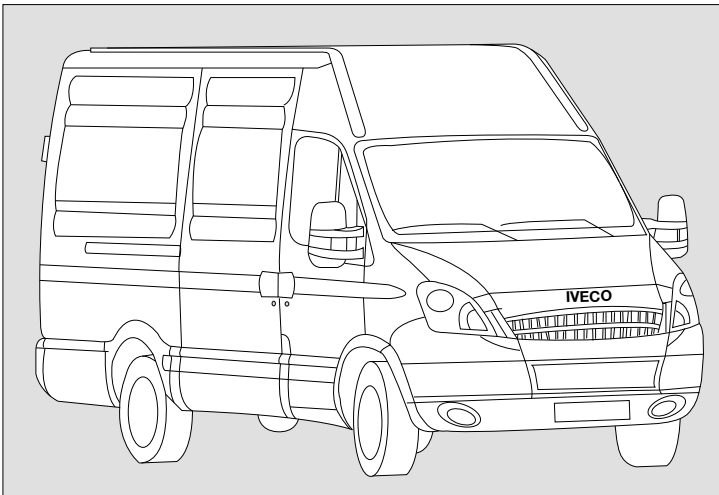

VEHICLE DETAILS

Manufacturer	Iveco
Make	Daily MY2012
Model	29L 11/13/15, 35S 11/13/15 35C 11/13, 40C 11/13
Engine CC	2286
Engine Details	Euro 5 F1A - 106/126/146
Year	10.2011>
Chassis Nos.	N/A
LHD	YES
RHD	YES
PAS	YES
A/C	NO
Voltage	12v

KIT DETAILS

Kit Part No.	0500.6842
Description	Standard Kit
Compressor RPM	3861/3564 @ Max Engine
	Power Output
Fitting Time	45 Minutes
Suction Fitting	90° (Max Height 48 mm)
Discharge Fitting	90° (Max Height 41 mm)
Belt Type	6PK 875
Belt Part No.	0820.6181
Note	Standard vehicle only (No 7196 Option)

FOREWORD

The purpose of this manual is to facilitate the installation of a direct drive compressor. The information given is merely instructive, should any complications arise contact the Technical department. The manufacturer's warranty does not cover any problems caused by defective installation or alterations made unless authorised. The manufacturer shall not be responsible for any injury, damage or loss caused directly or indirectly as a result of using this manual or the information contained within it.

1 SAFETY MEASURES:

Before fitting the Compressor adapter drive kit, ensure the following for damage:

- a Inner and outer trim and body work
- b Engine idle pace
- c Check all the vehicle functions

Check list:

- a Ensure that the right kit has been selected
- b Before installing, check that all the correct pieces are present; also ensure that there are no missing or broken pieces
- c When fitting, make sure the vehicle is properly protected against damage.

Installation apparatus

- a Calibrated torque wrench
- b Hand service tools
- c Protective covers and shields

2 PRECAUTIONS

- a Detach the battery negative lead.
- b Torque all bolts where stated using a calibrated torque wrench.
- c Take extreme care with moving parts.
- d Remove the vehicle's ignition key and keep it with you.
- e Wear safeguards and make sure that liquid refrigerant never touches your skin

Caution: Measures must be followed accurately to steer clear of the possibility of damage to individuals

Warning: This calls awareness to actions which must be pursued to avoid damage to the components.

NB: This calls awareness to make the job easier or gives useful information.

PRE-INSTALLATION

N.B Prior to commencing work, please examine the instructions with care. The alphabetical symbols on the diagram relate to written instructions, numerical symbols relate to the parts listing.

Dismantle the following:

1. Remove the engine under panel 2 x M6 Bolts and 4 x M8 self tapping screws.
2. Using a suitable tool rotate the automatic belt tensioner pulley (A) clockwise - Fig.1
3. Remove the original manufacturers poly groove drive belt (B) noting the original routing, if different from the diagram shown in Fig.1 report your findings to your Kit/System supplier before proceeding.
4. Remove and retain the four crankshaft pulley bolts (C) - Fig 2
5. Remove and retain the crankshaft damper (D) from the engine.

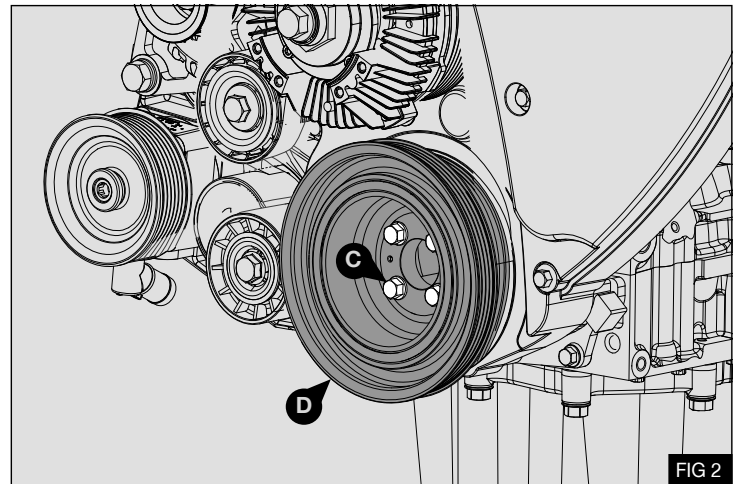
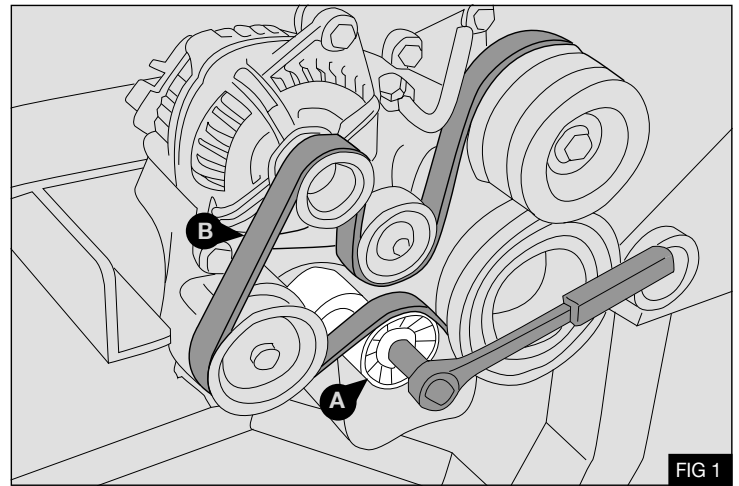

CRANKSHAFT PULLEY INSTALLATION

1. Align the supplied crankshaft pulley (5) with the pre drilled holes in the Iveco crankshaft damper (D).
2. Fit the supplied roll pins (17) through the supplied pulley (5) into the crankshaft damper (D) - Fig 3

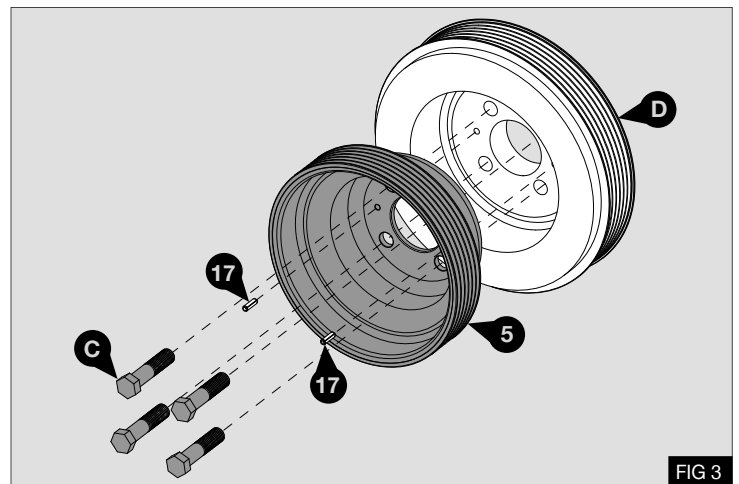

3. Refit crankshaft damper (D) and supplied compressor drive pulley (5) using original bolts (C) - Fig 4
4. Torque original bolts (C) to 30Nm / 22lb.ft.

Warning: Follow the procedure carefully to insure correct positioning of the compressor drive pulley.

5. Re-fit the original Alternator, Power steering & Fan Belt (B) into position shown in Fig 1

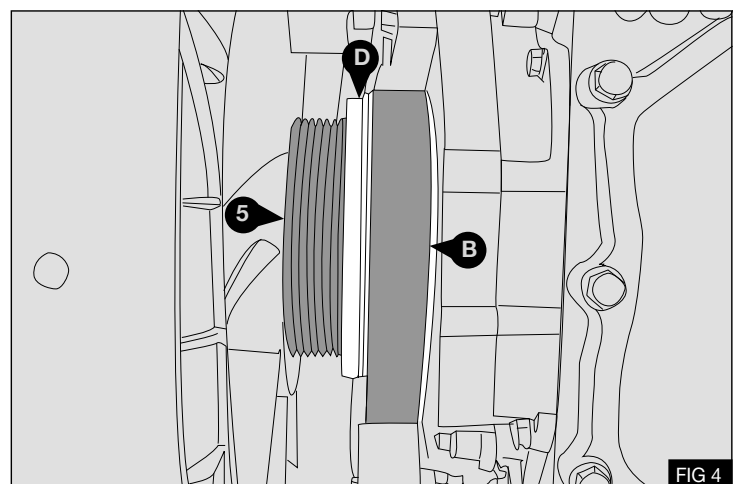

MOUNT BRACKET INSTALLATION

1. Fit the supplied Eccentric pulley (4) to the mount bracket (1) using bolt (9) M10 x 40, do not tighten at this stage - Fig 5

Warning: Fit the correct length bolts into the compressor mounting bracket (1)

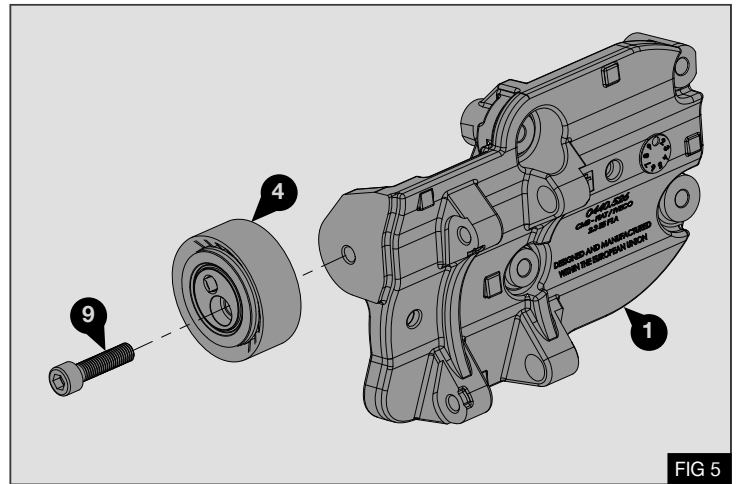

2. Fit the supplied compressor mount bracket (1) to the engine using the two bolts (11) M8 x 50 and one bolt (12) M8 x 40 and bolt (13) M8 x 35 - Fig 6
3. Torque bolts (11) (12) & (13) to 25Nm / 18Lb ft

NB: Please refrain from using "Loctite" unless otherwise notified

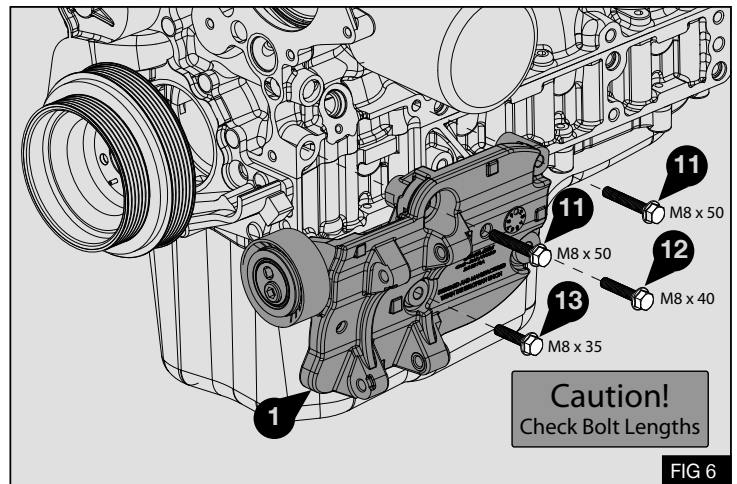

4. Fit the supplied clutch belt guard (19) to the compressor using the supplied bolts (8) (10) M10 x 30 & M10 x 35, M10 nuts (7) and washers (26) do not tighten bolts (8) (10) at this stage - Fig 7

Warning: Ensure washer (26) is positioned at point (X) between the guard and the compressor ear

Warning: If a Techni coil is fitted to the compressor discard washer (26) at point (X)

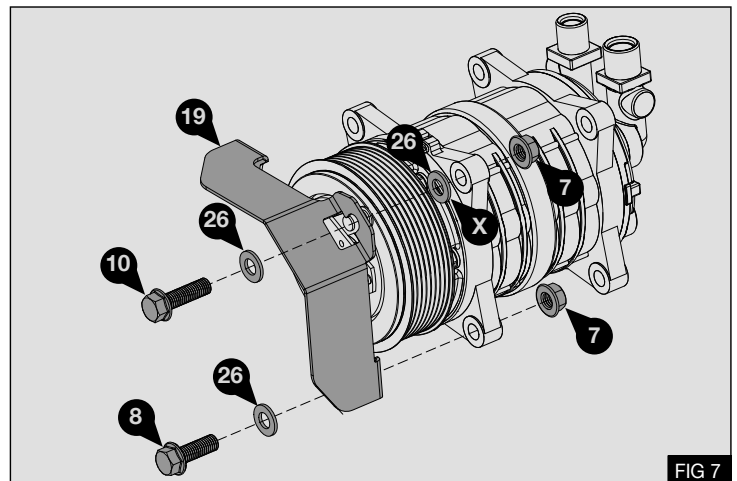

5. Fit the Compressor to Mount Bracket (1) using the four bolts (10) M10 x 35 and washer (26) in position shown - Fig 8
6. Torque bolts (10) to 50Nm / 37lb.ft.
7. Tighten the bolts (8) (10) securing the belt guard (19) Torque bolts to 50Nm / 37lb.ft.

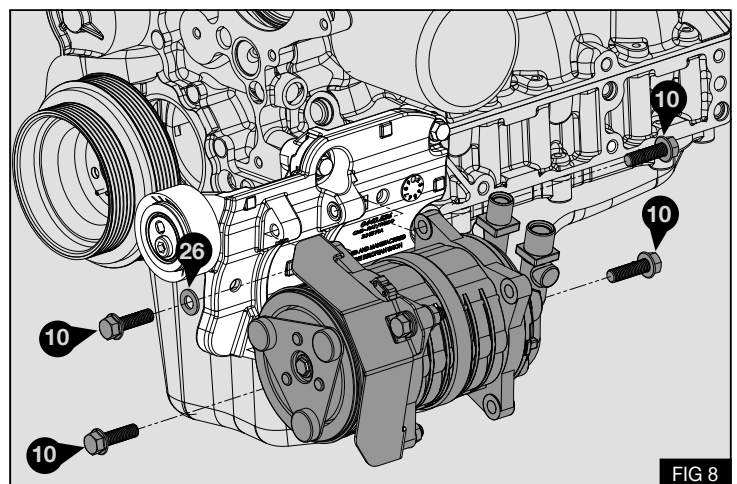

DRIVE BELT

1. Fit the Compressor Drive Belt (6) taking care to position the ribs of the belt in the respective grooves of the pulleys - Fig 9/10

NB: Where applicable and dependent on the compressor model, align the supplied drive belt by installing in the correct clutch groove - Fig.10

Seltec PV8 has the same gauge line (46.55) as the Sanden PV6 & PV7, belt is fitted to front groove.

Sanden PV8 has a unique gauge line (50.11) in most cases, belt is fitted to second groove. If in any doubt, please check with your compressor supplier

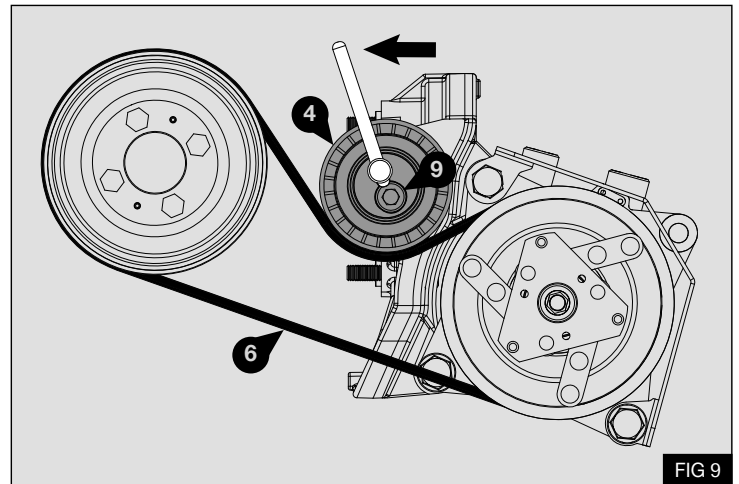

FIG 9

2. Tension the drive belt to correct tension (see table) using a suitable tool (1/4" Drive), tighten bolt (9), to lock eccentric pulley.
3. Torque bolt (9) to 50 Nm / 37 lb ft.

BELT TENSION TABLE		
Belt	Belt Age	Belt Tension Using the Belt Tension Gauge
6PK	New Belt	66 - 84 kg
6PK	Used Belt	54 - 60 kg

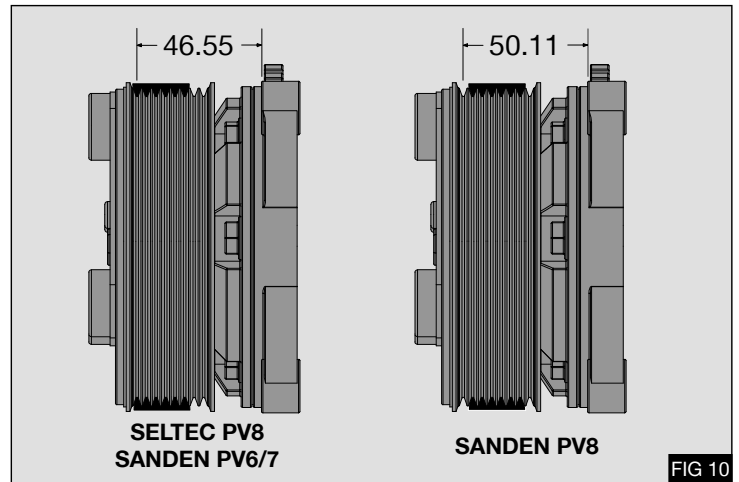

FIG 10

HOSE SUPPORT INSTALLATION

1. Temporarily remove the bolt (E) securing the starter motor - Fig 11
2. Fit the hose support bracket (20) and secure with the original bolt (E) - Fig 11
3. Torque bolt (E) to 30 Nm / 22 lb ft.

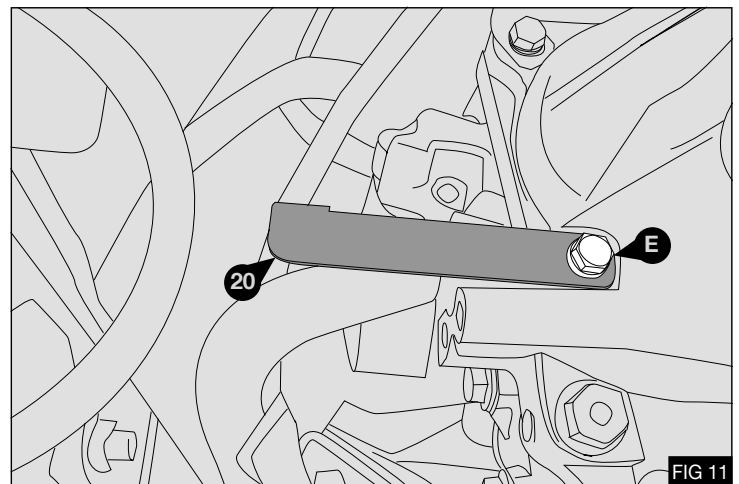

FIG 11

4. Secure the hose support bracket (22) to the original hole in the chassis using bolt (14) M6 x 25 with washer (16) and nut (15) - Fig 12
5. Torque bolt (14) to 10 Nm / 7.5 lb ft.

NB: Position washer (16) to the outside of the chassis.

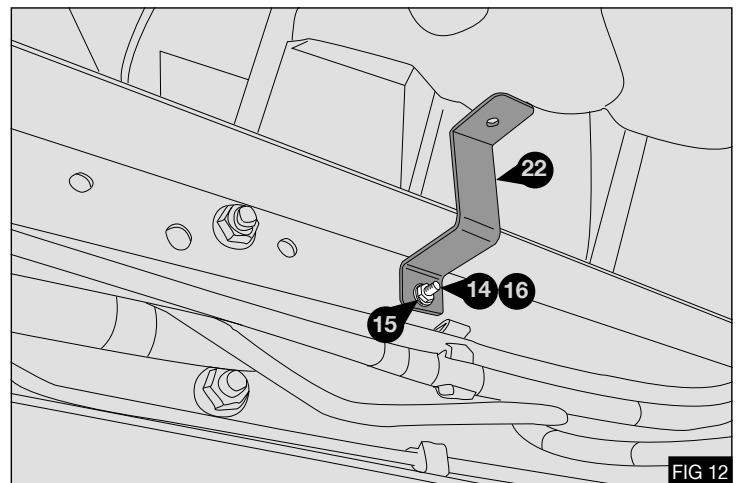
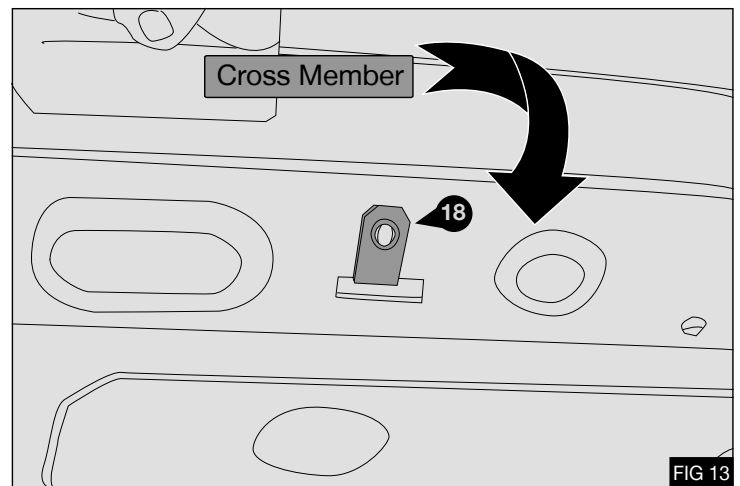

FIG 12

- Insert the supplied M6 lug nut (18) in to the hole provided in the chassis cross member at the position shown in Fig 13



HOSE INSTALLATION

- Check compressor hose fitting heights - Fig 14

Warning: Check compressor hose fitting heights Discharge
 © Max = 41mm, Suction © Max = 48mm - Fig 14

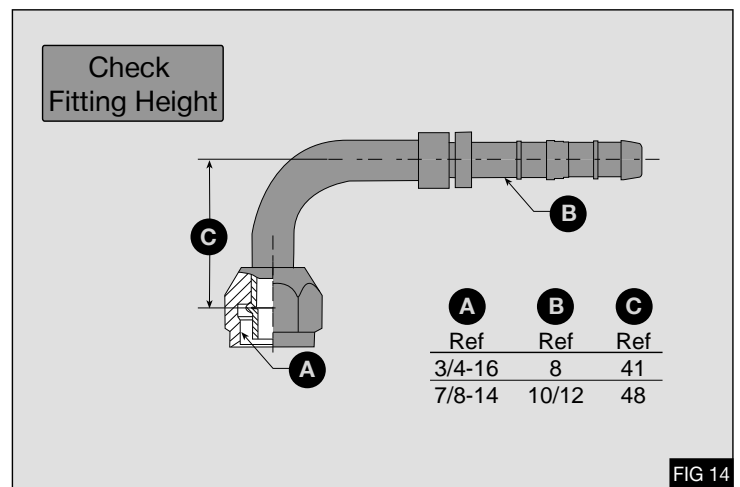

- Install the refrigerant fittings to the compressor and position hoses between the engine mount and the bottom radiator hose as shown in Fig 15

Warning: Position Suction and Discharge hoses, to achieve a minimum clearance of 20 mm at points (F), (G) - Fig 15

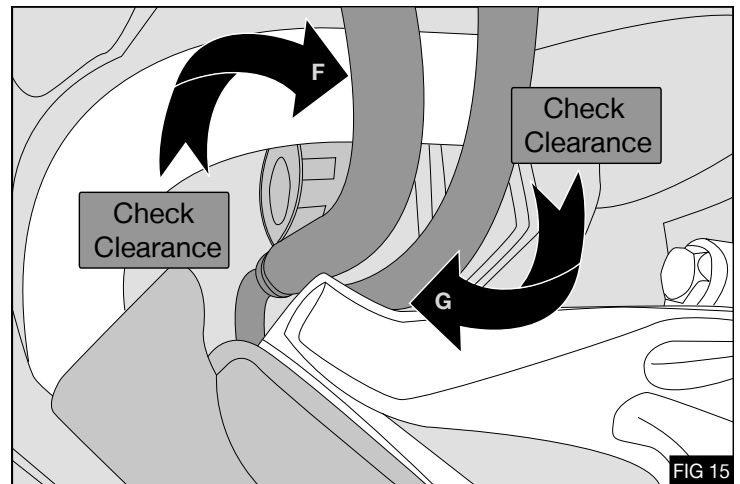

- Install the refrigerant hoses as shown in Fig 16 and secure using the supplied hose clamps (21) & (23) with bolt (14) M6 x 25 and M6 nut (15) - Fig 16

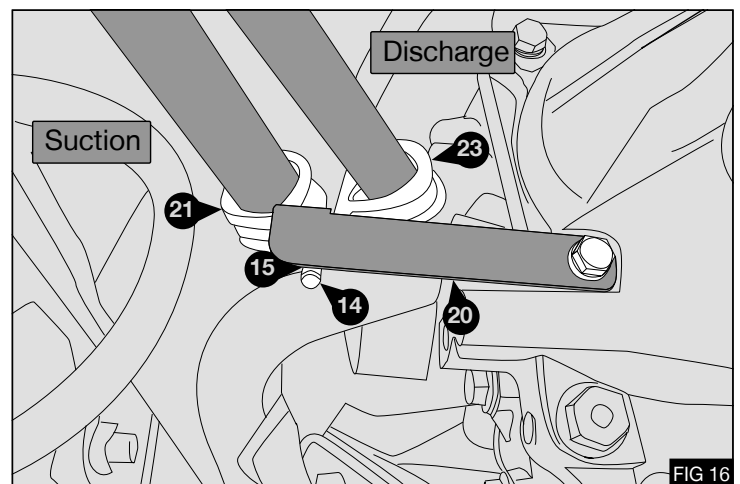

- Install the refrigerant hoses as shown in Fig 17 and secure using the supplied hose clamps (21) & (23) with bolt (14) M6 x 25 and M6 nut (15) - Fig 17

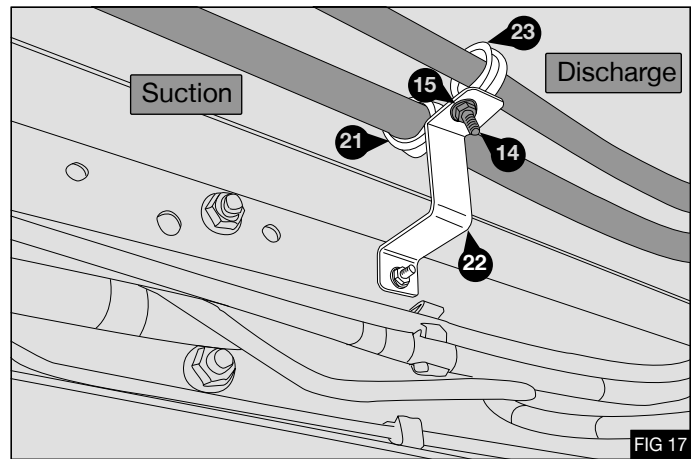

- Install the refrigerant hoses as shown in Fig 18 and secure using the supplied hose clamps (21) & (23) with bolt (14) - Fig 18

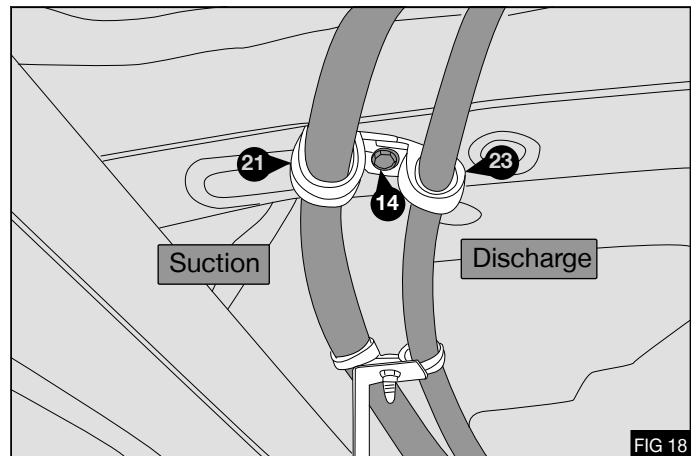

- Connect the supplied pipe clips (24) & (25) together as shown in Fig 19

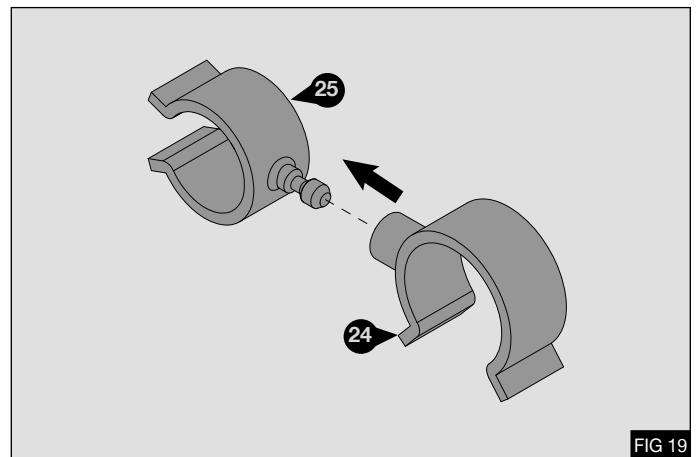

- Join Suction and Discharge hoses together at points shown using the pipe clips (24) & (25) previously joined together - Fig 20

Warning: Position hoses, brackets and pipe clips to achieve a minimum clearance of 30 mm at points (H), (I) and to all other components.

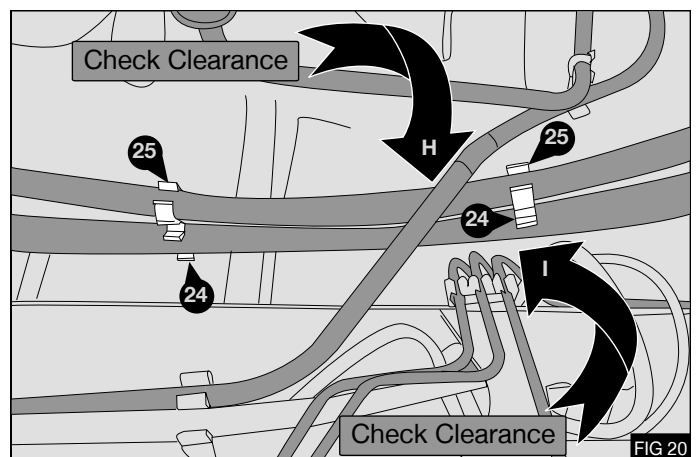

POST INSTALLATION

1. Before starting the engine check all the installed parts and ensure that the belt is installed correctly. Run the unit for at least ten minutes, then check the whole mounting assembly and previously removed parts. Attach the supplied warning label on to a suitable location.
2. Check Iveco fuel pipe is secure in its original clips and there is a minimum of 50 mm clearance between the compressor and the fuel pipe at point J.- Fig 21

Warning: Check clearance at point J, minimum clearance 50 mm - Fig 21

Warning: Check fuel pipe clip at point K is secure - Fig 21

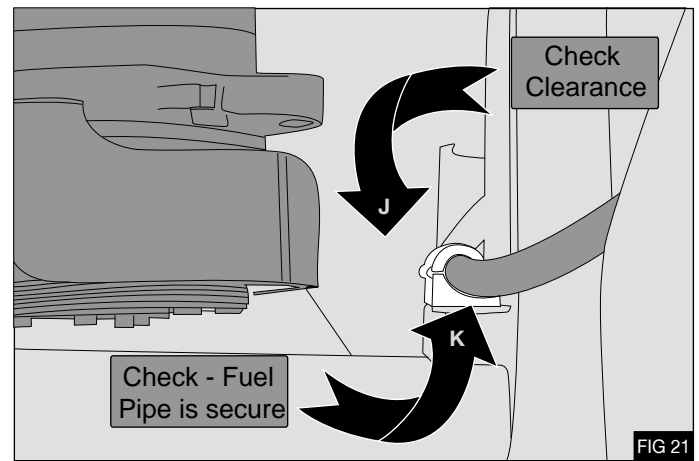

(EN)

Techni focuses on constant upgrading of its products. The Manufacturer reserves the right to modify the models and components described in the present publication at any time for technical or commercial reasons and without prior notice. For further information, contact Techni technical services.

(DE)

Techni ist stets bestrebt die eigenen Produkte zu verbessern. Die Herstellerfirma behält sich das Recht vor, aus technischen oder Verkaufsgründen, zu jeder Zeit und ohne vorherige Ankündigung, Abänderungen an den Modellen und den in dieser Veröffentlichung beschriebenen Einbauteile vorzunehmen. Für weitere Informationen bitten wir Sie, sich an unseren Techni Kundendienst zu wenden.

(FR)

Techni vise à une amélioration constante des ces produits. La maison se réserve le droit d'apporter, à tout moment et sans préavis, des modifications aux modèles et aux composants décrits dans cette publication pour des raisons d'ordre technique ou commerciale. Pour d'ultérieures informations s'adresser au service d'assistance Techni.

(IT)

Techni mira ad un costante miglioramento dei propri prodotti. La Casa si riserva il diritto di apportare in qualunque momento e senza preavviso modifiche ai modelli e ai componenti descritti in questa pubblicazione per ragioni di natura tecnica o commerciale. Per ulteriori informazioni rivolgersi al servizio assistenza Techni.

(ES)

Techni aspira a un constante mejoramiento de su producción. La Fábrica se reserva el derecho de aportar en cualquier momento y sin preaviso modificaciones a los modelos y los componentes descritos en esta publicación por razones técnicas o comerciales. Para ulteriores informaciones dirigirse al servicio asistencia Techni.

VENDITA E SERVIZIO
VENTE ET SERVICE

SALES AND SERVICE
VERKAUF UND SERVICE



Sundorne Trade Park, Henley Way,
Shrewsbury, United Kingdom, SY1 4NS
Telephone (+44) (0) 1743 443176
Fax (+44) (0) 1743 443113
Email: sales@techni.co.uk